



SPECIFICATION FOR APPROVAL

Customer Name:

Customer P/N:

Product Name: Electronic ballast for UV-Lamps

Model NO.: PH11-425-2/21U

Supplire P/N:

Rev: A1.0

Date: 2022-08-16

Approved by Yue Jia		
Checked	Rechecked	Approved

Please send the original back to us after you have approved and signed.

Approved by customer		
Comments	Approved	Company's seal
Customeris Name:		



Electronic Ballast

www.fsyuejia.com

PH11-425-2/21U

APPLICATION and PERFORMANCE SPECIFICATION



- Shell material Aluminum
- Europe type terminal structure
- Green and red led indicate operating status
- Potential free relay contact on/off out
- Must cut off the power before installation and replacement ballast
- Diameter of wire 0.5~0.75mm², Wire stripping 8~10mm
- No moer than 5 meters distance between the ballast and lamp
- Ballasts case must be grounded



Technical - Electrical Data	Conditions	Min	Nom	Max	Unit
Voltage Range		110	220	240	Vac
Input Frequency			50/60		Hz
Input Current				0.42@110V 0.2@240V	A
Input Power				46	W
Power Factor	Full Load		>0.95		PF
Lamp Output Power				41	W
Lamp Output Current		0.4		0.45	A
Efficiency	Full Load		>90		%
Preheat start, Suitable for more times startup			>20000		Times
Lamp Preheat Current		0.5		0.7	A
Lamp Preheat Time		3		4	S
Technical - Temperatures					
Maximum operating temperature at the Tc				+85	°C
Ambient temperature range Ta		-25		+50	°C
Relative Humidity		5		85	%
Safety and Protection					
Protection	Overload Protection Lamp Air Leakage Protection Over Heat Protection Protection Against Moisture				
Isolation Class	Class I				
Isolation Voltage	1.5KV AC / 5mA / 5s				
Protection Class	IP20				
Warranty period	2 years				
Normen und Approval					
Safety Norm	EN61347-1-2-3, EN62493				
LVD Norm	Low voltage Directive 2014/35/EU				
EMC Norm	EN55015, EN55014, GB17743, GB17625, EN61000-3-2				
Certifications	CE RoHS				
Packaging units					
Packaging units Pieces/ Unit	Shipping carton box (**pcs/CTN)				
Dimensions in L x W x H	**.*cm x **.*cm x **.*cm				
Gross weight	*****kg				
Volume	*****CBM.				

Technical - Geometries

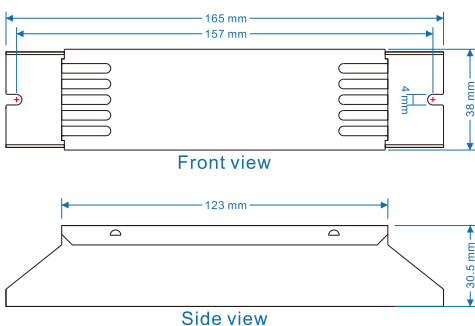

Technical - Wiring diagram

